

REV-5

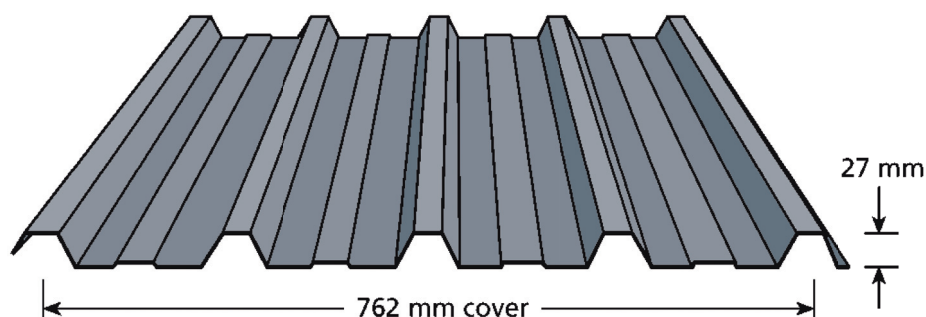

FEATURES & BENEFITS

- 762mm coverage.
- Improved lapping & capillary action.
- Choice of pans & stiffeners in varying profiles.
- Suitable for both roofing & cladding applications.

The distinct lines allow the profile to create contemporary finish allowing the REV-5 to be the perfect solution for domestic and commercial applications. REV-5 can be used as both a roofing and walling product. REV-5 provides economy with its 762mm coverage as well as versatility in all applications.

The subtle square shaped rib of 27mm ensures greater strength, spanning capability, lightness and rigidity enabling the optimisation of the roof design for a cost effective outcome. With its ease of installation roofers have used this reliable and strong profile for over 40 years.

MATERIAL SPECIFICATIONS

Revolution Roofing only use 100% BlueScope Steel products.

ZINCALUME® steel aluminium/zinc alloy-coated steel complying with AS1397-2001 G550, AZ150 (550MPa minimum yield stress, 150g/m² minimum coating mass); or Stainless Steel standard grade designation is AISI/ASTM Type 430; UNS No. S43000.

COLORBOND® steel metal thickness is 0.35, 0.42 or 0.48mm. G550, AZ150 (550MPa minimum yield stress, 150g/m² minimum coating mass).

COLORBOND® Ultra base metal thickness is 0.42 or 0.48mm. G550, AZ200 (550MPa minimum yield stress, 200g/m² minimum coating mass).

COLORBOND® steel .60 Blue Orb G300, AZ150 (300Mpa minimum yield stress, 150g/m² minimum coating mass).

COLORBOND® Metallic steel base metal thickness is 0.48mm. G550, AZ150 (550Mpa minimum yield stress, 150g/m² minimum yield stress, 150g/m² minimum coating mass).

The COLORBOND® prepainted steel complies with AS/NZS2728:1997.

MINIMUM ROOF PITCH 2 DEGREES

For REV-5 a minimum roof pitch of 2 degrees is recommended.

TOLERANCE & MASSES

REV-5 Masses						
Measurement	Zincalume 0.35 BMT	Colorbond 0.35 BMT	Zincalume 0.42 BMT	Colorbond 0.42 BMT	Zincalume 0.48 BMT	Colorbond 0.48 BMT
kg/m	2.74	2.79	3.26	3.32	3.7	3.76
kg/m ²	3.60	3.67	4.28	4.35	4.86	4.93
m ² /t	278	272	234	230	206	203

Tolerances

Length: +0mm/ -15mm Width: +4mm/ -4mm

The REV-5 has been tested to the following standards:

- AS 1562.1 - 1992 Design and installation of sheet roof and wall cladding
- AS 4040 - 1992 Methods of testing sheet roof and walling cladding - Part 0: Introduction, list of methods and general requirements - Part 2: Methods of testing sheet roof and wall cladding - Resistance to wind pressures for non-cyclone regions
- The REV-5 is manufactured to AS1397 and AS2728 standards.
- The REV-5 requires installation to follow the AS1445 and AS1565 standards following the HB39 code.



Zincalume® Colorbond®

REV-5

SPAN TABLE NON-CYCLONIC

Revolution Roofing REV-5 Recommended Maximum Support Spacings (mm) SPAN TABLE		
Type of Roof Span BMT (mm)	0.42	0.48
Single Span	1100	1600
End Span	1250	1900
Internal Span	1800	2600
Unstiffened Eaves Overhang	200	250
Stiffened Eaves Overhang	350	350

Revolution Roofing REV-5 Recommended Maximum Support Spacings (mm) SPAN TABLE			
Type of Wall Span BMT (mm)	0.35	0.42	0.48
Single Span	1700	2300	2700
End Span	2200	2750	3100
Internal Span	2400	2900	3200
Stiffened Eaves Overhang	300	300	350

Note:

1. For roofing the data is based on foot traffic loading.
2. For walling the data is based on wind pressure.
3. The above data table is based on supports of 1mm BMT.
4. 0.35 BMT is recommended for walling applications only.

STANDARD INTERPRETATION OF SPANS

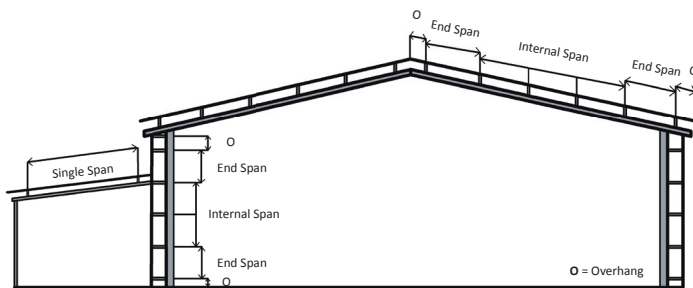

Design Parameters

Region A: $C_{p,e} = 0.65$
 Terrain Category 2 $C_{p,i} = 0.20$
 Height = 10m $P_u = 2.25 \text{ kPa}$
 $K_L = 2.0$ $P_s = 1.93 \text{ kPa}$

SERVICEABILITY AND STRENGTH

Non-Cyclonic 0.42 BMT NON-CYCLONIC Wind Uplift Resistance - Service and Strength Limit State Design					
Span (mm)	End Span (Trend)		Span (mm)	Internal Span (Trend)	
	Serviceability (kPa)	Strength (kPa)		Serviceability (kPa)	Strength (kPa)
900	3.27	6.07	1200	3.13	5.91
1200	2.43	4.94	1500	2.43	4.93
1500	1.77	4.06	1800	1.85	4.13
1800	1.24	3.35	2100	1.37	3.46

Non-Cyclonic 0.48 BMT NON-CYCLONIC Wind Uplift Resistance - Service and Strength Limit State Design					
Span (mm)	End Span (Trend)		Span (mm)	Internal Span (Trend)	
	Serviceability (kPa)	Strength (kPa)		Serviceability (kPa)	Strength (kPa)
900	3.49	7.18	1200	3.39	7.10
1200	2.25	6.05	1500	2.34	6.14
1500	1.29	5.17	1800	1.48	5.36
1800	0.50	4.45	2100	0.76	4.69

Cyclonic 0.42 BMT & 0.48 BMT Lo Hi Lo - CYCLONIC Wind Uplift Resistance - Strength Limit State Design to BCA 2010				
Span (mm)	0.42 BMT		0.48 BMT	
	End Span (kPa)	Internal Span (kPa)	End Span (kPa)	Internal Span (kPa)
900	7.02		7.60	
1200	4.43	6.55	5.03	7.14
1500	2.97	4.39	3.42	4.98
1800	2.07	3.16	2.50	3.63
2100	1.50	2.44	2.01	2.82
2400		1.82		2.29

REV-5

FASTENER SPACING NON-CYCLONIC

Crest Fastener Location
4 fasteners per sheet - end supports and end laps



Pan Fastener Location
4 fasteners per sheet - end supports and end laps

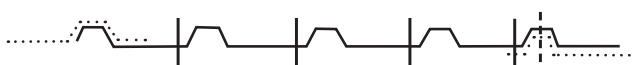

Note: Most common practice is: 4 fasteners for internal spans and 4 fasteners for single and end spans, equating to 5-6 screw per square metre.

FASTENER SPACING CYCLONIC

Crest Fastener Location
4 fasteners per sheet - end supports and end laps



Pan Fastener Location
4 fasteners per sheet - end supports and end laps

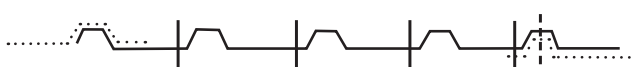

Note: Most common practice is: 4 fasteners for internal spans and 5 fasteners for single and end spans.

Maximum Support Spacings

The maximum recommended support spacings are based on testing in accordance with AS1562.1-1992, AS4040.1-1992 and AS4040.2-1992. The recommended roof spans take in to consideration both resistance to wind pressure and light roof traffic (traffic arising from maintenance). The wall spans take in to consideration the resistance to wind pressure only.

Note: After exposure of cladding to an extreme wind event, it is recommended that inspection be performed to confirm cladding integrity.

* The above data displayed is based on trend data, which is a true representation of the average product capability.

REV-5

INSTALLATION & SCREWS NON-CYCLONIC

Side Laps

Revolution Roofing recommend using side lap fasteners at mid spans when using the REV-5 at its maximum length. This ensures the sheet laps are held firmly in place and help reduce the possibility of future leaks that arise from expansion and contraction. The edge of the REV-5 with its improved capillary action should always be used as the underlap. When cladding is supported, side lap fasteners are generally not needed for extra strength.

End Laps

End laps are not generally required as REV-5 is available in long lengths, however if they are necessary for a certain application please contact your nearest Revolution Roofing office for information regarding the sequence of laying and the amount of overlap.

Turning of Sheetting Ends

It is common practice to overlap sheets into gutters by 50mm when the roof pitch is 25 degrees or in extreme weather areas. The pans of the sheets should be turned down at lower ends and turned up at upper ends. When REV-5 is laid on a pitch less than 5 degrees, cut back the corner of the undersheet, at the downhill end of the sheet to block capillary action.

Lengths

Sheets are supplied custom cut to long lengths.

CREST OR PAN FIXING

REV-5 can be crest or pan fixed to timber or steel supports with the recommended fasteners no less than 30mm from sheet ends.

Fixing to Steel

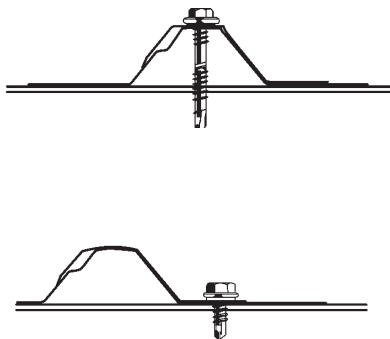

Fixing to Timber

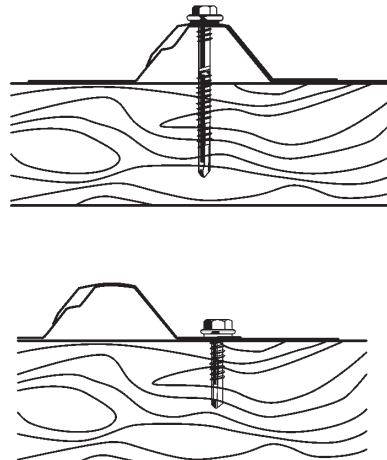

REV-5 Non-Cyclonic Pierce Fixing		
Type	Fixing to Steel	Fixing To Timber
Crest Fixed	M6.2-13 x 50mm Hex Head HG/Seal	M6.2-13 x 50mm Hex Head HG/Seal
Pan Fixed	10-16 x 16mm Metal Tek's hexagon head with seal	M6-11 x 25mm Roofzips hexagon head with seal
Side Lap & Accessories	Self drilling needle point stitching screws with hex, slot-head EPDM seal: 8-15 x 15 alternatively self drilling screws with hex, washer-head & EPDM seal:10-16 x 16 or sealed blind rivets: 4.8mm diameter aluminium.	

REV-5 Cyclonic Pierce Fixing		
Type	Fixing to Steel	Fixing To Timber
Crest Fixed	M6.2-13 x 50mm Hex Head HG/Sea + Squarelok washers 5-691-01-010-2C4, 1mm thick, class 4	M6.2-13 x 50mm Hex Head HG/Seal + Squarelok washers 5-691-01-010-2C4, 1mm thick, class 4
Pan Fixed	10-16 x 16mm Metal Tek's hexagon head with seal + Squarelok washers 5-691-01-010-2C4, 1mm thick, class 4	M6-11 x 25mm Roofzips hexagon head with seal + Squarelok washers 5-691-01-010-2C4, 1mm thick, class 4
Side Lap & Accessories	Self drilling needle point stitching screws with hex, slot-head EPDM seal: 8-15 x 15 alternatively self drilling screws with hex, washer-head & EPDM seal:10-16 x 16 or sealed blind rivets: 4.8mm diameter aluminium.	