

REV-KLIP 700

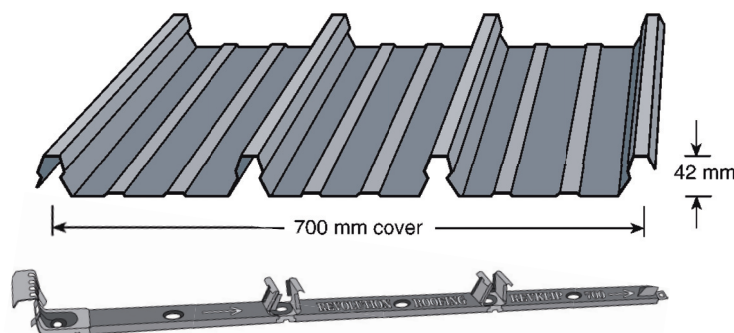

FEATURES & BENEFITS

- 700mm coverage.
- 3 pan concealed fix profile.
- Screw fixed option.
- Squared shoulders with a distinct & classically smooth finish.
- Mobile mill option available., long straight runs can be rolled on site to your length requirements.
- Suitable for roofing & walling applications.

MATERIAL SPECIFICATIONS

Revolution Roofing only use 100% BlueScope Steel products.

ZINCALUME® steel aluminium/zinc alloy-coated steel complying with AS1397-2001 G550, AZ150 (550MPa minimum yield stress, 150g/m² minimum coating mass); or Stainless Steel standard grade designation is AISI/ASTM Type 430; UNS No. S43000.

COLORBOND® steel metal thickness is 0.35, 0.42 or 0.48mm. G550, AZ150 (550MPa minimum yield stress, 150g/m² minimum coating mass).

COLORBOND® Ultra base metal thickness is 0.42 or 0.48mm. G550, AZ200 (550MPa minimum yield stress, 200g/m² minimum coating mass).

COLORBOND® steel .60 Blue Orb G300, AZ150 (300Mpa minimum yield stress, 150g/m² minimum coating mass).

COLORBOND® Metallic steel base metal thickness is 0.48mm. G550, AZ150 (550Mpa minimum yield stress, 150g/m² minimum yield stress, 150g/m² minimum coating mass).

The COLORBOND® prepainted steel complies with AS/NZS2728:1997.

MINIMUM ROOF PITCH 1 DEGREE

For REV-KLIP 700 a minimum roof pitch of 1 degree is recommended.

TOLERANCE & MASSES

REV-KLIP 700 Masses				
Measurement	Zincalume 0.42 BMT	Colorbond 0.42 BMT	Zincalume 0.48 BMT	Colorbond 0.48 BMT
kg/lm	3.26	3.32	3.70	3.76
kg/m ²	4.65	4.74	5.29	5.37
m ² /t	215	211	189	186

Tolerances

Length: +7mm/ -7mm Width: +4mm/ -4mm

The REV-KLIP 700 has been tested to the following standards:

- AS 1562.1 - 1992 Design and installation of sheet roof and wall cladding
- AS 4040 - 1992 Methods of testing sheet roof and walling cladding - Part 0: Introduction, list of methods and general requirements - Part 2: Methods of testing sheet roof and wall cladding - Resistance to wind pressures for non-cyclone regions
- The REV-KLIP 700 is manufactured to AS1397 and AS2728 standards.
- The REV-KLIP 700 requires installation to follow the AS1445 and AS1565 standards following the HB39 code.



Zincalume® Colorbond®

REV-KLIP 700

INSTALLATION & SCREWS NON-CYCLONIC

Using the recommended fasteners, fix the first clip, with the arrow of the clip pointing towards the area to be laid at a 90 degree angle to the gutter in a straight line. Please endeavour to ensure the overlaps face away from the wind.

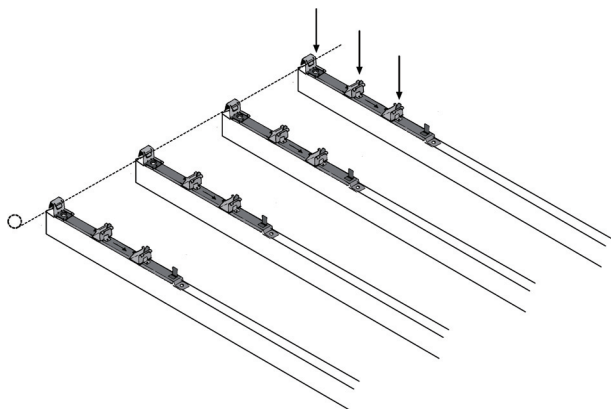

Fix first sheet to clips using downward pressure ensuring deck is properly engaged into clip. Check there is adequate overhang of the sheet to the eaves line.

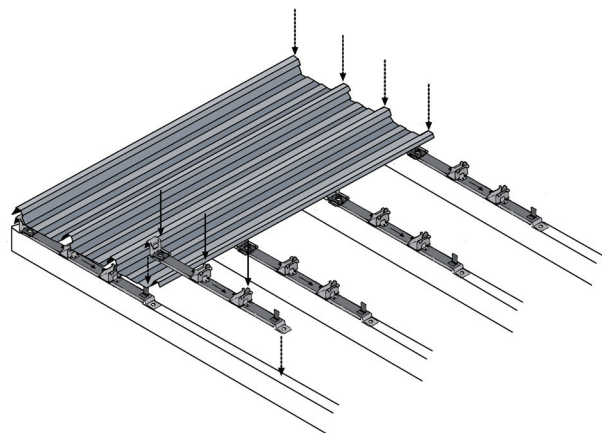

Fix next clip to previous clip using locating tab and position the strap of the clip over the top of the male rib, then fix next sheet engaging the female rib into the male rib with the strap of the clip in between.

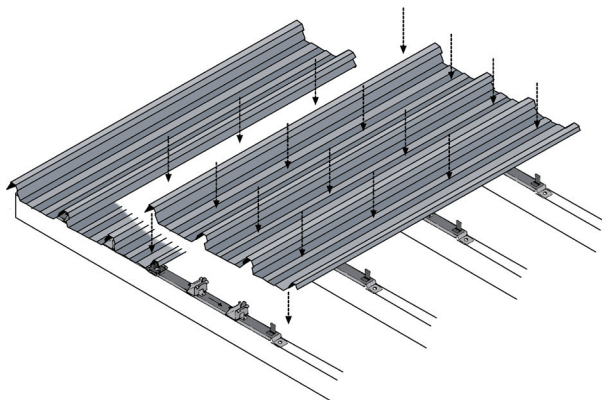

Continue fixing clips for deck in same manner, check periodically with a string line that the deck is properly aligned.

Sheet Ends

At the end of the purlins, cut the deck and the clip to suit. It is recommended to allow roof sheets to overlap into gutters by about 50mm.

Turn up REV-KLIP 700 pans at the ridge line. Pans should be turned down at the gutter line of lower pitches.

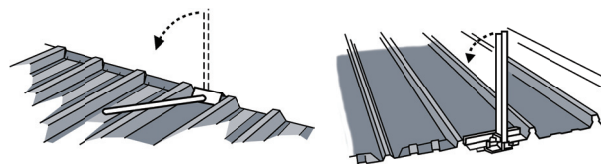

Lengths

Sheets are provided at your required length, including lengths too long for standard transport. Revolution Roofing also offer an on site rollforming service for continuous on site rolling, further information can be found on page 4 of this section.

CLIP FIXING

Concealed fixing is the method of fixing sheets using fasteners, which do not pass through the sheet. Instead, the cladding is held in place with clips. The screws below are for clip fastening only.

REV-KLIP 700 Clip Fixing (Non-Cyclonic)	
Type	Fixing to Steel (up to 3mm)
With Insulation	10 - 16 x 25mm Metal Tek's hexagonal head with seal
Without Insulation	10 - 16 x 25mm Metal Tek's hexagonal head with seal

*Note: When fixing to timber please contact your Revolution Roofing representative for more information or refer to the pan fixing guide.

REV-KLIP 700

PAN FIXING

REV-KLIP 700 can be pan fixed to timber or steel supports with the recommended fasteners no less than 30mm from sheet ends.

This is common fixing practice for verandah and canopy situations, where the use of clips is not required. We recommend you speak with your Revolution Roofing staff member prior to fixing.

Fixing to Steel

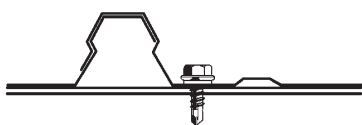

Fixing to Timber

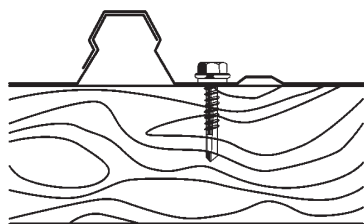

Span Table Non-Cyclonic

Revolution Roofing REV-KLIP 700 Recommended Maximum Support Spacings (mm) SPAN TABLE		
Type of Roof Span BMT (mm)	0.42	0.48
Single Span	1600	2000
End Span	1700	2550
Internal Span	2100	3000
Unstiffened Eaves Overhang	150	150
Stiffened Eaves Overhang	500	500
Type of Wall Span BMT (mm)	0.42	0.48
Single Span	2100	2300
End Span	2100	2700
Internal Span	2400	2900
Unstiffened Eaves Overhang	300	400
Stiffened Eaves Overhang	300	400

Note:

1. For roofing the data is based on foot traffic loading.
2. For walling the data is based on wind pressure.
3. The above data table is based on supports of 1mm BMT.

LOAD SPAN TABLE

Span (mm)	REV-KLIP 700 Clip Fixed Deck G550 0.42 BMT NON-CYCLONIC Wind Uplift Resistance		REV-KLIP 700 Clip Fixed Deck G550 0.48 BMT NON-CYCLONIC Wind Uplift Resistance	
	Double & End Span*		Double & End Span*	
	0.42 BMT		0.48 BMT	
	Serviceability (kPa)	Strength (kPa)	Serviceability (kPa)	Strength (kPa)
1200	1.48	2.65	1.73	3.00
1500	1.26	2.20	1.65	2.37
1800	1.08	1.84	1.58	1.86

*The above data displayed is based on Trend Data, which is a true representation of the average product capability.

Required Fixings: Clips Revolution REV-KLIP 700 clip, 1 screw per rib
Screws Self drilling metal screws 12 gauge - 14 tpi x 20mm length

Note: Double span results are applicable to both end spans and internal spans for continuous sheets. After exposure of cladding to an extreme wind event, it is recommended that inspection be preformed to confirm cladding integrity.

REV-KLIP 700

This page has been intentionally left blank